

Load diagrams

213.2 ft

32.8	49.2	65.6	82.1	98.1	98.4	114.8	131.2	147.6	164.1	180.4	196.8	213.2	ft
11,023	11,023	11,023	11,023	11,023	10,988	9,224	7,910	6,892	6,082	5,421	4,773	4,409	lbs
32.8	49.2	59.1	65.6	95.5	98.4	114.8	131.2	147.6	164.1	180.4	196.8	213.2	ft
11,023	11,023	11,023	11,023	11,023	10,657	8,893	7,646	6,561	5,752	5,090	4,541	4,078	lbs
32.8	49.2	51.8	65.6	82.1	98.4	114.8	131.2	147.6	164.1	180.4	196.8	213.2	ft
22,046	22,046	22,046	16,942	13,150	10,657	8,893	7,646	6,561	5,752	5,090	4,541	4,078	lbs

196.8 ft

32.8	49.2	65.6	82.1	98.4	108.3	114.8	131.2	147.6	164.1	180.4	196.8	ft
11,023	11,023	11,023	11,023	11,023	11,023	10,329	8,874	7,747	6,989	6,118	5,511	lbs
32.8	49.2	65.6	82.1	98.4	105.3	114.8	131.2	147.6	164.1	180.4	196.8	ft
11,023	11,023	11,023	11,023	11,023	11,023	9,998	8,543	7,416	6,519	5,787	5,181	lbs
32.8	49.2	57.1	65.6	82.1	98.4	114.8	131.2	147.6	164.1	180.4	196.8	ft
22,046	22,046	22,046	18,913	14,713	11,951	9,998	8,543	7,416	6,519	5,787	5,181	lbs

180.4 ft

32.8	49.2	65.6	82.1	98.4	114.8	115.5	131.2	147.6	164.1	180.4	ft
11,023	11,023	11,023	11,023	11,023	11,023	11,023	9,557	8,353	7,394	6,614	lbs
32.8	49.2	65.6	82.1	98.4	112.5	114.8	131.2	147.6	164.1	180.4	ft
11,023	11,023	11,023	11,023	11,023	11,023	10,781	9,226	8,023	7,064	6,283	lbs
32.8	49.2	60.7	65.6	82.1	98.4	114.8	131.2	147.6	164.1	180.4	ft
22,046	22,046	22,046	20,307	15,820	12,870	10,781	9,226	8,023	7,064	6,283	lbs

164.1 ft

32.8	49.2	65.6	82.1	98.4	114.8	119.7	131.2	147.6	164.1	ft
11,023	11,023	11,023	11,023	11,023	11,023	11,023	9,958	8,710	7,716	lbs
32.8	49.2	65.6	82.1	98.4	114.8	116.8	131.2	147.6	164.1	ft
11,023	11,023	11,023	11,023	11,023	11,023	11,023	9,627	8,380	7,385	lbs
32.8	49.2	62.9	65.6	82.1	98.4	114.8	131.2	147.6	164.1	ft
22,046	22,046	22,046	21,129	16,471	13,408	11,243	9,627	8,380	7,385	lbs

147.6 ft

32.8	49.2	65.6	82.1	98.4	121.1	131.2	147.6	ft	
11,023	11,023	11,023	11,023	11,023	11,023	10,079	8,818	lbs	
32.8	49.2	65.6	82.1	98.4	114.8	117.8	131.2	147.6	ft
11,023	11,023	11,023	11,023	11,023	11,023	11,023	9,749	8,488	lbs
32.8	49.2	63.4	65.6	82.1	98.4	114.8	131.2	147.6	ft
22,046	22,046	22,046	21,376	16,667	13,572	11,380	9,749	8,488	lbs

131.2 ft

32.8	49.2	65.6	82.1	114.8	119.4	131.2	ft	
11,023	11,023	11,023	11,023	11,023	11,023	9,921	lbs	
32.8	49.2	65.6	72.2	82.1	98.4	124.1	131.2	ft
11,023	11,023	11,023	11,023	11,023	11,023	11,023	10,362	lbs
32.8	49.2	65.6	66.9	82.1	98.4	114.8	131.2	ft
22,046	22,046	22,046	22,046	17,657	14,392	12,081	10,362	lbs

114.8 ft



32.8	49.2	65.6	82.1	98.4	114.8	ft	
11,023	11,023	11,023	11,023	11,023	11,023	lbs	
32.8	49.2	65.6	72.2	82.1	111.5	114.8	ft
11,023	11,023	11,023	11,023	11,023	11,023	11,023	lbs
32.8	49.2	65.6	68.2	82.1	98.4	114.8	ft
22,046	22,046	22,046	22,046	18,029	14,700	12,346	lbs

98.4 ft

32.8	49.2	65.6	82.1	98.4	ft	
11,023	11,023	11,023	11,023	11,023	lbs	
32.8	49.2	65.6	72.2	82.1	98.4	ft
11,023	11,023	11,023	11,023	11,023	11,023	lbs
32.8	49.2	62.3	65.6	82.1	98.4	ft
22,046	22,046	22,046	20,851	16,250	13,228	lbs

Counterweight blocks

	213.2 ft			196.8 ft			180.4 ft			164.1 ft		
	A	B	C	A	B	C	A	B	C	A	B	C
	8	-	-	8	-	-	7	-	-	7	-	-
	48,502 lbs			48,502 lbs			42,439 lbs			42,439 lbs		

	147.6 ft			131.2 ft			114.8 ft			98.4 ft		
	A	B	C	A	B	C	A	B	C	A	B	C
	6	1	-	6	-	-	5	-	-	4	-	-
	39,683 lbs			36,376 lbs			30,313 lbs			24,251 lbs		



Mechanisms

45Hp 10T (33Kw) - INV - 5V

400V - 50HZ / 60HZ

H.U.H. 413.4ft S/R Ø0.04ft



H.U.H. LEBUS 1049.9ft S/R Ø0.04ft





		ft/min	0-20.6	0-108.2	0-147.6	0-213.2	0-291.9	0-10.2	0-54.1	0-73.8	0-106.6	0-145.9
		lbs	11,023	11,023	7,716	4,409	2,756	22,046	22,046	15,432	8,818	5,511
	LEBUS 2408.1ft	Kw	33	33	33	33	33	33	33	33	33	33





* 57Hp (42Kw) - INV - 5V

400V - 50HZ / 60HZ



H.U.H. LEBUS 984.2ft S/R Ø0.04ft

		ft/min	0-20.6	0-131.2	0-150.9	0-232.9	0-337.9	0-10.2	0-65.6	0-75.4	0-116.4	0-168.9
		lbs	11,023	11,023	7,716	4,409	2,756	22,046	22,046	15,432	8,818	5,511
	1968.5 ft	Kw	42	42	42	42	42	42	42	42	42	42

	ft/min	36.1 / 121.4 / 246.1		
	Kw	4,5		
	r.p.m.	0,3	0,6	0,9
	Nm	2 x 65		
* 	r.p.m.	0,3	0,6	0,9
Inverter	Kw	2 x 5,5		
	ft/min	39.4 / 78.7		
	Kw	4 x 3		

- * Optional
-  Hoisting
-  Trolleying
-  Slewing
-  Travelling
-  Rope

		400 V 50 Hz	328.1 ft 4x0.0004 ft ²	GEN SET 120 kVA	INSTALLED POTENCY 60 KW
---	---	----------------	--------------------------------------	--------------------	-------------------------------

		400 V 60 Hz	328.1 ft 4x0.0004 ft ²	* Optional
---	---	----------------	--------------------------------------	------------

FEM 1005-C25-C50-D50 / EN 14439 - Masts / Reactions

- K = S17 8/8
- L = S17 16/8
- N = S21 - S17 8/8
- O = S21 8/8
- P = S21 16/8
- T = S2322 16/16 M45L
- U = S2326 16/16 M52L
- X = C2322/21

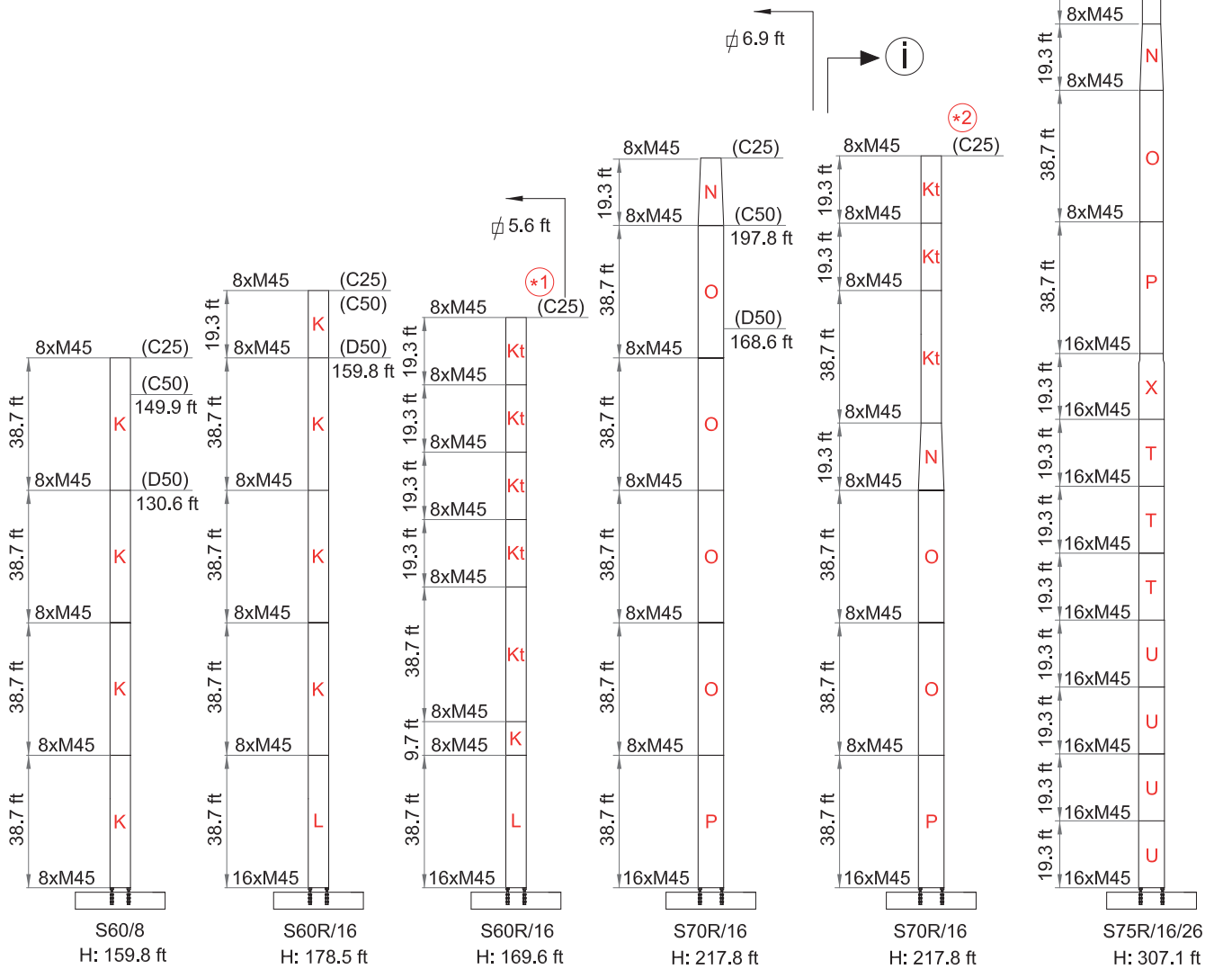
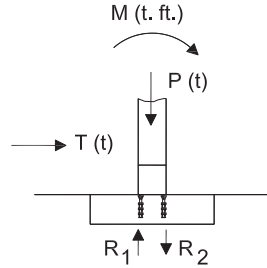

C25	H (ft)	82.3	101.7	121.1	159.8	169.6	179.1	198.5	217.8	307.1
-----	--------	------	-------	-------	-------	-------	-------	-------	-------	-------

FEM 1005-C25-C50-D50 / EN 14439 -Base ballast block

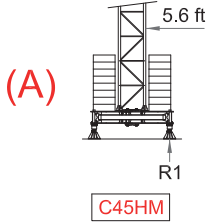

C25	H (ft)	84.9	94.8	104.3	114.2	124.1	133.8	143.7	153.5
	R1 (lbs)	147,489	155,426	164,465	174,165	184,527	196,211	220,462	251,988
	Z (lbs)	134,041	134,041	134,041	134,041	150,796	167,551	184,306	201,061
C50	H (ft)	84.9	94.8	104.3	114.2	124.1	133.8	143.7	153.5
	R1 (lbs)	154,764	156,087	165,126	175,929	184,968	214,730	249,343	286,821
	Z (lbs)	134,041	134,041	134,041	134,041	150,796	167,551	184,306	234,572
D50	H (ft)	84.9	94.8	104.3	114.2	124.1	133.8		
	R1 (lbs)	155,205	156,308	180,338	214,951	252,650	293,215		
	Z (lbs)	134,041	134,041	134,041	150,796	201,061	217,817		

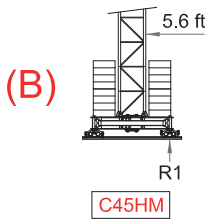

C25	H (ft)	84.3	94.2	103.7	113.5	123.3	133.2	143.1	152.9
	R1 (lbs)	147,489	155,426	164,465	174,165	184,527	196,211	220,462	251,988
	Z (lbs)	134,041	134,041	134,041	134,041	150,796	167,551	184,306	201,061
C50	H (ft)	84.3	94.2	103.7	113.5	123.3	133.2	143.1	152.9
	R1 (lbs)	154,764	156,087	165,126	175,929	184,968	214,930	249,343	286,821
	Z (lbs)	134,041	134,041	134,041	134,041	150,796	167,551	184,306	234,572
D50	H (ft)	84.3	94.2	103.7	113.5	123.3	133.2		
	R1 (lbs)	155,205	156,308	180,338	214,951	252,650	293,215		
	Z (lbs)	134,041	134,041	134,041	150,796	201,061	217,817		

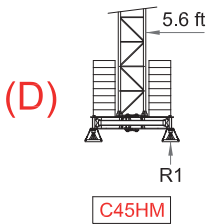

C25	H (ft)	86.6	96.4	105.9	115.8	125.6	135.5	145.3	155.2
	R1 (lbs)	147,489	155,426	164,465	174,165	184,527	196,211	220,462	251,988
	Z (lbs)	134,041	134,041	134,041	134,041	150,796	167,551	184,306	201,061
C50	H (ft)	86.6	96.4	105.9	115.8	125.6	135.5	145.3	155.2
	R1 (lbs)	154,764	156,087	165,126	175,929	184,968	214,730	249,343	286,821
	Z (lbs)	134,041	134,041	134,041	134,041	150,796	167,551	184,306	234,572
D50	H (ft)	86.6	96.4	105.9	115.8	125.6	135.5		
	R1 (lbs)	155,205	156,308	180,338	214,951	252,650	293,215		
	Z (lbs)	134,041	134,041	134,041	150,796	201,061	217,817		

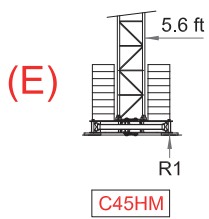

C25	H (ft)	83.9	103.3	113.2	123.1	132.9	142.7	152.5	162.4
	R1 (lbs)	147,489	164,465	174,165	184,527	196,211	220,462	251,988	288,585
	Z (lbs)	134,041	134,041	134,041	150,796	167,551	184,306	201,061	268,082
C50	H (ft)	83.9	103.3	113.2	123.1	132.9	142.7	152.5	
	R1 (lbs)	147,489	164,465	174,165	184,527	196,211	220,462	251,988	
	Z (lbs)	134,041	134,041	134,041	150,796	167,551	184,306	201,061	
D50	H (ft)	83.9	103.3	113.2	123.1	132.9			
	R1 (lbs)	147,489	164,465	174,165	184,527	196,211			
	Z (lbs)	134,041	134,041	134,041	150,796	167,551			

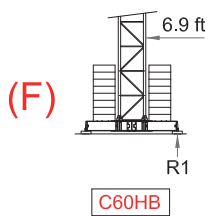

C25	H (ft)	84.9	94.5	104.3	123.7	133.2	143.1	162.4	181.7
	R1 (lbs)	108,026	117,065	124,341	132,057	137,568	158,292	205,912	261,248
	Z (lbs)	100,531	100,531	100,531	100,531	117,286	134,041	167,551	234,572
C50	H (ft)	84.9	94.5	104.3	123.7	133.2	143.1	162.4	181.7
	R1 (lbs)	113,097	120,813	127,868	134,923	156,969	158,292	133,910	263,673
	Z (lbs)	100,531	100,531	100,531	117,286	134,041	150,796	184,306	217,817
D50	H (ft)	84.9	94.5	104.3	123.7	133.2	143.1	162.4	
	R1 (lbs)	114,640	123,459	136,025	187,172	215,832	246,918	280,648	
	Z (lbs)	100,531	100,531	100,531	134,041	150,796	184,306	201,061	

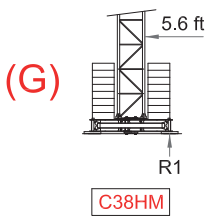

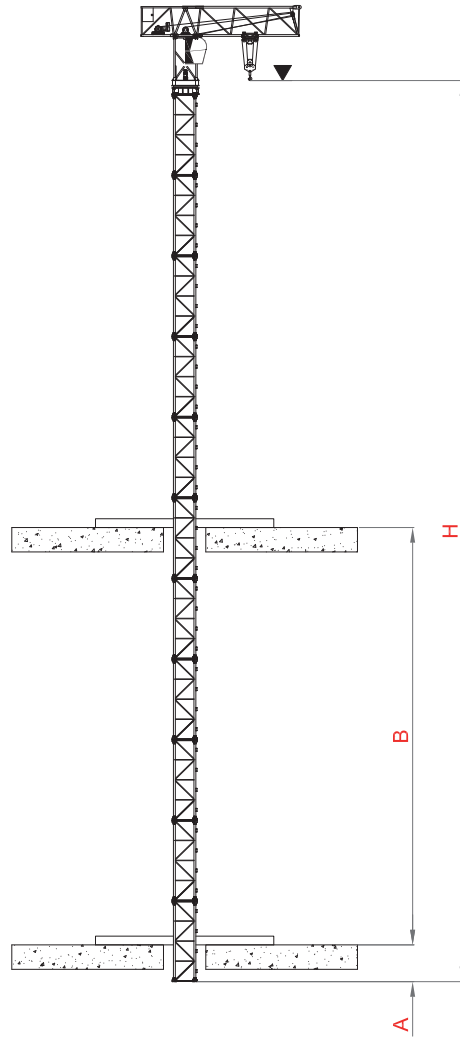

C25	H (ft)	83.9	93.8	103.7	113.5	123.3	133.2		
	R1 (lbs)	177,472	187,393	195,991	210,321	223,328	237,438		
	Z (lbs)	150,796	167,551	167,551	201,061	217,817	234,572		
C50	H (ft)	83.9	93.8	103.7	113.5	123.3	133.2		
	R1 (lbs)	179,015	190,479	198,195	213,407	224,871	264,334		
	Z (lbs)	150,796	167,551	167,551	201,061	217,817	234,572		
D50	H (ft)	83.9	93.8	103.7	113.5	123.3			
	R1 (lbs)	180,338	191,361	221,564	263,452	309,529			
	Z (lbs)	150,796	167,551	167,551	217,817	234,572			

BOTTOM CLIMBING CRANE

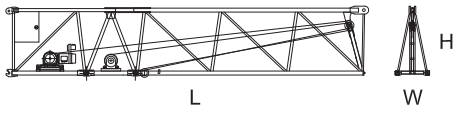
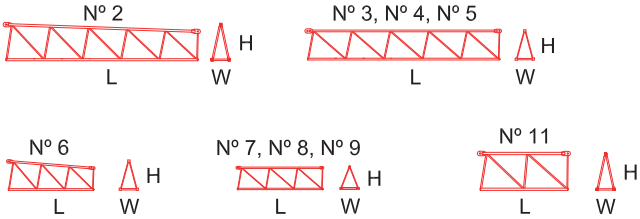
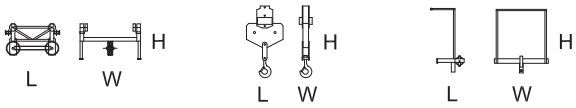
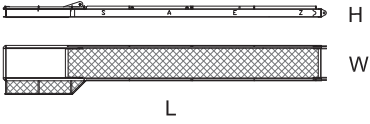

ⓘ Consult us

	L(ft)	W(ft)	H(ft)	Weight(lbs)	
Jib heel section 	39.1	4.1	7.5	13,735	
Intermediate jib section 					
	2R	38.1	3.7	7.4	5,304
	3R	38.1	3.7	5.9	4,266
	4R	17.4	3.7	5.9	1,417
	5	17.4	3.7	5.9	1,168
	6	17.4	3.7	5.9	1,036
	7	17.4	3.7	4.7	0,829
	8	17.4	3.7	4.7	0,719
	9	16.9	3.7	4.6	0,547
	11R	16.9	3.7	7.4	2,932
Hook, Trolley and jib head 					
		5.1	4.4	2.6	0,639
		2.6	0.5	4.9	0,727
		2.6	3.9	4.6	0,238
Counter-jib 	39.2	5.9	1.9	5,677	
Counterweight blocks 					
	A	11.5	4.1	0.9	6,063
	B	6.0	4.1	0.9	3,307

L(ft) W(ft) H(ft) Weight(lbs)

Crossbase 4,5x4,5

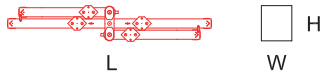

21.9 3.6 3.9 12,676

Half base beams



(x2)

14.4 0.9 1.8 0,485

Base ballast block



1443.6 0.9 3.9 8,377

Foundation anchor

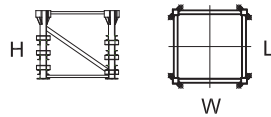

S60/8 6.1 6.1 5.2 2,108

S60/R16 6.1 6.1 5.2 2,443

S70/8 7.4 7.4 5.2 2,473

S70R/16 7.4 7.4 5.2 2,809

Dima



S75R16/20 1.1 1.1 5.2 2,645

S75R16/22 1.6 1.6 6.6 6,261

S75R16/26 1.6 1.6 7.9 6,967

S75R24/26 1.6 1.6 7.9 7,496

Dima 7.6 7.7 2.6 3,638

Levellers

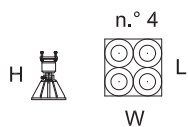

n.º 4

(x4)

3.9 3.9 2.9 0,551

Travelling bogies

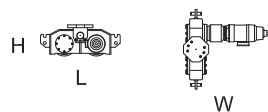

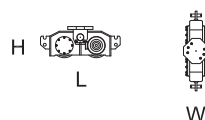

(x2)

3.8 4.1 1.5 1,113

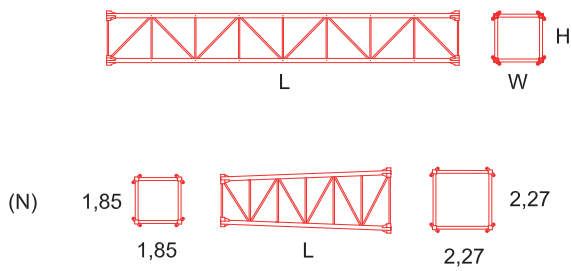
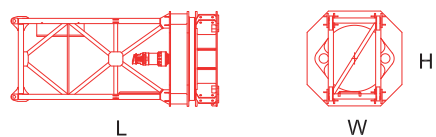
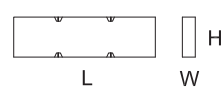

(x2)

3.8 0.8 1.5 0,992

	L(ft)	W(ft)	H(ft)	Weight(lbs)	
Tower section					
	K	38.7	6.1	6.1	10,141
	K	19.3	6.1	6.1	5,450
	K	9.8	6.1	6.1	3,141
	L	38.7	6.1	6.1	12,169
	O	38.7	7.4	7.4	11,120
	O	19.3	7.4	7.4	5,820
	O	9.8	7.4	7.4	3,406
	P	38.7	7.4	7.4	12,566
	N	19.3			7,716
	X	19.7	7.4	7.5	8,818
	T	19.7	7.4	7.5	9,480
	U	19.7	10.8	7.7	13,029
Z	19.7	8.5	7.7	13,184	
ZR	19.7	10.8	7.7	17,685	
Complete slewing unit					
	14.4	6.5	6.5	14,991	
Base support block					
	12.3	1.6	3.9	11,905	
Cabin and platform					
	9.8	3.8	7.7	1,230	
Main base beam C60HB					
	28.4	2.5	3.1	9,480	

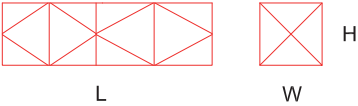
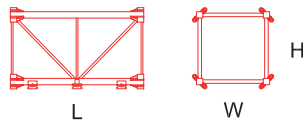
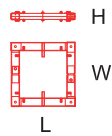
		L(ft)	W(ft)	H(ft)	Weight(lbs)
Half base beam C60HB 		14	2.2	3.2	4,464
Climbing cage type K Full 		K-9.7 24.1 K-19.3 36.7	6.9	6.9	14,109 17,637
Steel frame					K-9.7 10,781 K-19.3 14,308
Hydraulic and accessories					K-9.7 3,329 K-19.3 3,329
Tower section Kt 		9.7 19.3 38.7	6.1	6.1	3,252 5,670 10,472
Tie-frame 		7.6	7.6	0.8	2,094



40" HC x 6 - H.U.H. 121.1 ft



x 6 - H.U.H. 121.1 ft

