

Crane OMV 31A SR with jib horizontal and inclined 10° and 15°.

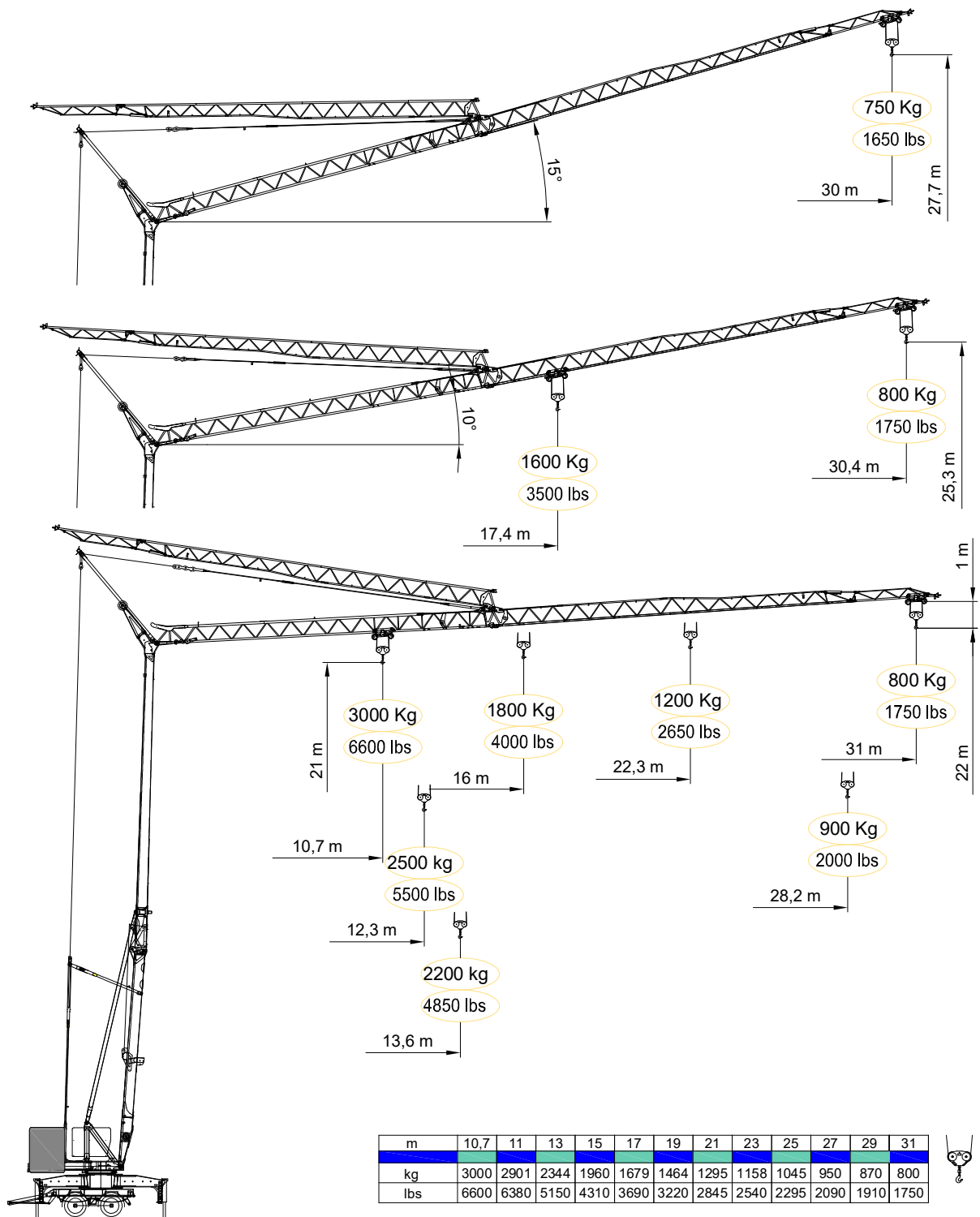

OMV 31A SR

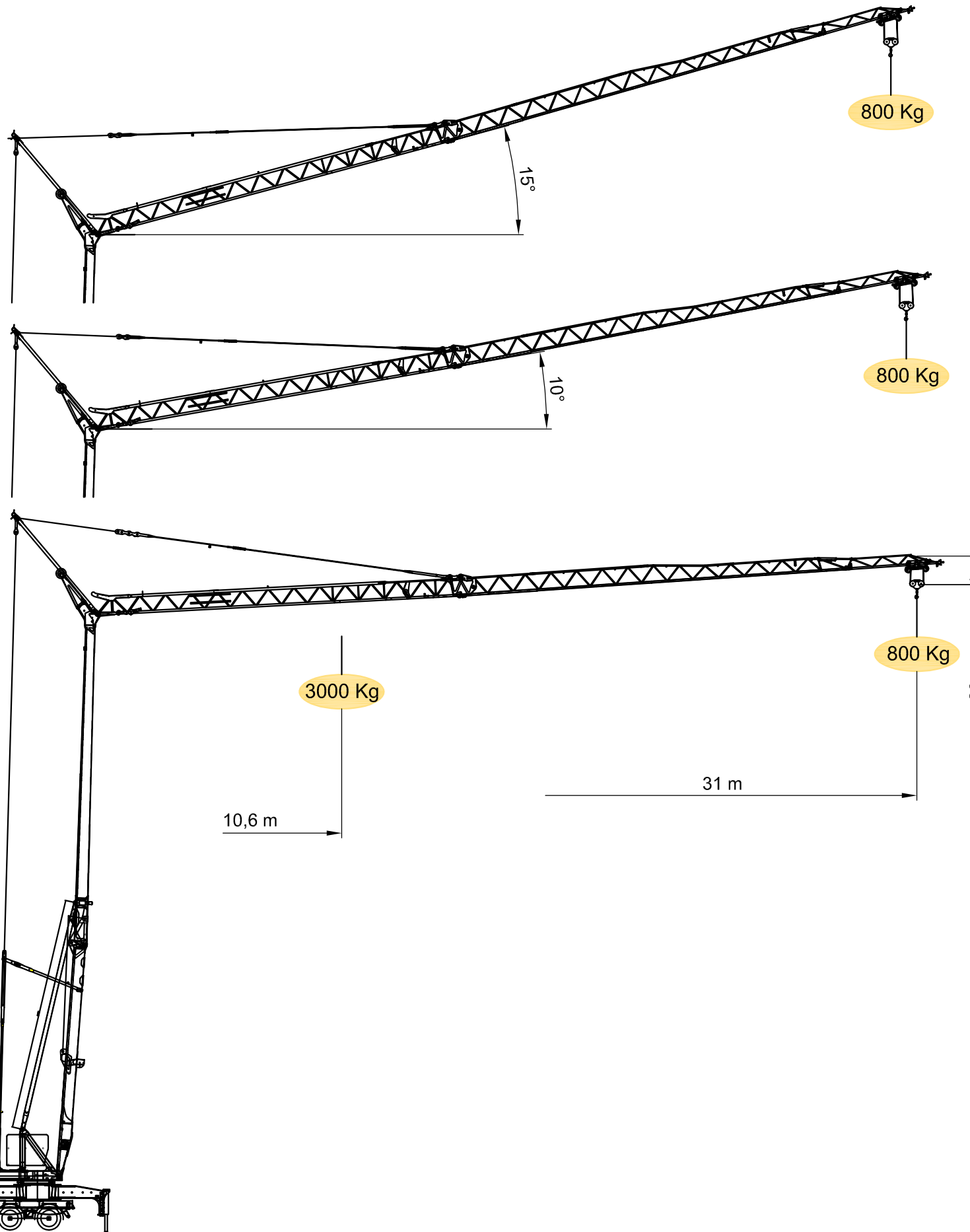

DOTAZIONE DI SERIE

Sollevamento "overdrive" a 4 velocità con inverter, rotazione e carrello a tre velocità con inverter, zincatura della struttura e dei tiranti, contrappeso, braccio impennabile, carrello rampante con motore e finecorsa alla base della torre, funzionamento con braccio ripiegato, comando a pulsantiera via cavo, carter di protezione per ralla e meccanismi, predisposizione per radiocomando, armadio elettrico in acciaio inox, documentazione a norme CEE.

STANDARD FEATURES

4-speed lifting, 3-speed rotation and trolley with inverter control, galvanised structure, counterweight, pull-up jib, translation trolley with motor and limit switch at base of gantry, operation with folden jib, cable-operated pushbutton remote control, guard for slewing ring and mechanisms, designed to allow installation of radio control, stainless steel electrical cabinet, documentation in accordance with EU standards.

EQUIPEMENT DE SERIE

Levage à quatre vitesses, chariot et rotation à trois vitesses à contrôle électronique, galvanisation de la structure et des tirants, contrepoids, flèche relevable, moteur de chariot et fin de course à la base de la tour, fonctionnement bras replié, commande par câble, carter de protection pour la couronne et les mécanismes, predisposition pour commande radio, armoire électrique en acier inox, documentation conforme aux normes CEE.

SERIENAUSSTATTUNG

Heben mit vier Geschwindigkeiten, Laufkatze und Rotation mit drei Geschwindigkeiten. Strukturverzinkung, Gegengewicht, hochklappbarer Arm, aufsteigender Wagen mit Motor und Anschlag an der Basis des Turms, Funktionieren mit eingeklapptem Arm, Steuerung mit Druckknopftaste via Kabel, Schutzvorrichtungen für Drehverbindungen und Mechanismen, Vorbereitung für Funksteuerung, elektrischer Schrank aus rostfreiem Stahl, Dokumentation gemäß EC Vorschriften.

DOTACION DE SERIE

Levantamiento a cuatro velocidades, carro y rotación a tres velocidades con control electrónico, galvanización de la estructura, contrapeso, brazo empinable, carro rampante con motor y fin de carrera en la base de la torre, funcionamiento con brazo replegado, funcionamiento por pulsadores via cable, carter de protección para corona de giro y mecanismos, predisposición para radiocomando, armario eléctrico de acero inox, documentación según normas CEE.

	400V (±10%) 50 Hz	12kVA			
	m/l'	6	20	42	50
	kg	3000	3000	1200	800
	kW	11 (Inverter)			
	m/l'	17.8	28.6	53.5 (↖39.3)	
	kW	3 (Inverter)			
	n/l'	0.17	0.42	0.85	
	kW	3,7 (Inverter)			
	min	18			
	kW	2.2			
	25 - 80 km/h		22.600 kg		2 x 4200 kg + 1715 kg

